

LIMITED WARRANTY

Products manufactured by GRUNDFOS PUMPS CORPORATION (GRUNDFOS) are warranted to the original user only to be free of defects in material and workmanship for a period of 18 months from date of installation, but not more than 24 months from date of manufacture. GRUNDFOS' liability under this warranty shall be limited to repairing or replacing at GRUNDFOS' option, without charge, F.O.B. GRUNDFOS' factory or authorized service station, any product of GRUNDFOS manufacture. GRUNDFOS will not be liable for any costs of removal, installation, transportation, or any other charges which may arise in connection with a warranty claim. Products which are sold but not manufactured by GRUNDFOS are subject to the warranty provided by the manufacturer of said products and not by GRUNDFOS' warranty. GRUNDFOS will not be liable for damage or wear to products caused by abnormal operating conditions, accident, abuse, misuse, unauthorized alteration or repair, or if the product was not installed in accordance with GRUNDFOS' printed installation and operating instructions.

To obtain service under this warranty, the defective product must be returned to the distributor or dealer of GRUNDFOS products from which it was purchased together with proof of purchase and installation date, failure date, and supporting installation data. Unless otherwise provided, the distributor or dealer will contact GRUNDFOS or an authorized service station for instructions. Any defective product to be returned to GRUNDFOS or a service station must be sent freight prepaid; documentation supporting the warranty claim and/or a Return Material Authorization must be included if so instructed.

GRUNDFOS WILL NOT BE LIABLE FOR ANY INCIDENTAL OR CONSEQUENTIAL DAMAGES, LOSSES, OR EXPENSES ARISING FROM INSTALLATION, USE, OR ANY OTHER CAUSES. THERE ARE NO EXPRESS OR IMPLIED WARRANTIES, INCLUDING MERCHANTABILITY OR FITNESS FOR A PARTICULAR PURPOSE, WHICH EXTEND BEYOND THOSE WARRANTIES DESCRIBED OR REFERRED TO ABOVE.

Some jurisdictions do not allow the exclusion or limitation of incidental or consequential damages and some jurisdictions do not allow limitations on how long implied warranties may last. Therefore, the above limitations or exclusions may not apply to you. This warranty gives you specific legal rights and you may also have other rights which vary from jurisdiction to jurisdiction.



GRUNDFOS PUMPS CORPORATION • 2555 Clovis Avenue • Clovis, CA • 93612

Area Centers: Allentown, PA • Atlanta, GA • Chicago, IL • Clovis, CA • Dallas, TX • Seattle, WA

(800) 333-1366 • FAX (800) 333-1363

Canada: Mississauga, Ontario • Mexico: Apodaca, N.L.

LKP-TL-001 Rev. 1/97
PRINTED IN USA

"The AP & KP"

Sump and Utility Pumps
Models KP 150 - 250
AP 12

Installation and Operating Instructions

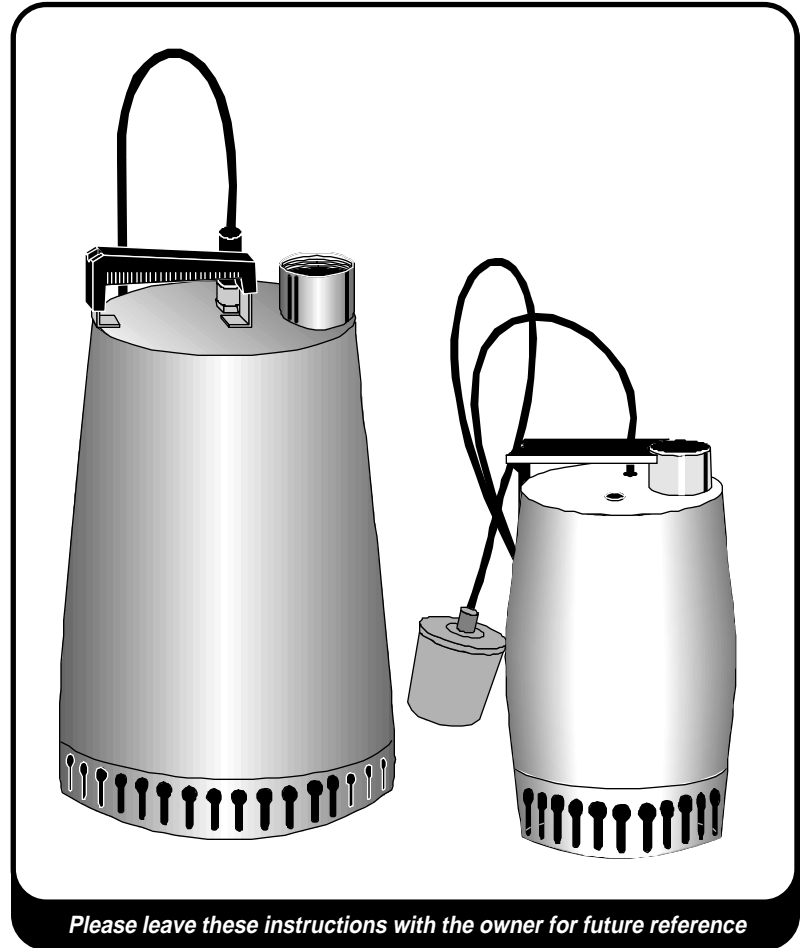

Please leave these instructions with the owner for future reference



Pre-Installation Checklist

4. Is the Application Correct for This Pump ?

SUITABLE APPLICATIONS

"The AP/KP" pumps are single-stage submersible pumps suitable for pumping waste water. The pump is capable of pumping water which contains solids up to 3/8"(KP),7/16"(AP) in diameter. The pump is suitable for:

- Drainage of cellars or buildings prone to flooding,
- Pumping of waste water from washing machines, sinks, baths, showers, etc., up to the sewer level.
- Dewatering of sites or excavations or the pumping of water for fountains.
- Pumping in draining wells
- Emptying swimming pools, ponds, tanks, or fountains (**except when there are persons in the water**).

UNSUITABLE APPLICATIONS

The pump **IS NOT** suitable for pumping:

- Sewage
- Liquids containing long fibers
- Liquids containing solid particles larger than 3/8"(KP),7/16"(AP) in diameter.
- Flammable liquids (oil, gasoline, etc.)
- Aggressive liquids

Note: If the pump has been used for very dirty or chlorinated water it should be flushed thoroughly with clean water after use.

5. Read this Guide Thoroughly

Even if you are very familiar with the installation of this pump, a quick glance through the remaining sections of this guide may help you avoid a potential problem.

Installation and Operation

Handling the Pump

It is recommended that a cable be secured to the pump handle to make it easier to remove the pump.

Do not lower or lift the pump by means of the electric cord.

Electrical Connection

The electrical connection should be carried out in accordance with local regulations and following the National Electrical Code. The pump should be grounded. The operating voltage and frequency are marked on the nameplate.

"THE AP/KP" pumps have built-in thermal overload protection and require no additional motor protection. If the motor is overloaded, it will stop automatically. When it has cooled to normal temperature it will start automatically.

Maintenance

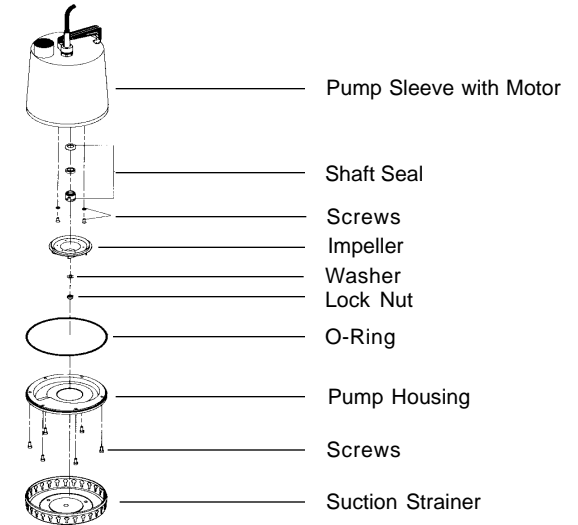

Fig. 2 AP 12

Troubleshooting

Problem	Cause
1. Motor does not start	a) Supply failure. b) Pump switched off by float switch c) Fuses are blown. d) Thermal relay has cut out the electricity supply to the motor (see Electrical Connection — pg.2).
2. Thermal relay trips out after short time of operation.	a) Temperature of pumped liquid higher than stated under "Pumped Liquid Requirements" on pg.1. b) Pump partly blocked by particles (see "Cleaning the Pumps" — pg.5). c) Pump mechanically locked (see "Cleaning the Pumps" — pg.5).
3. Pump runs but gives insufficient water.	a) Strainer partly blocked by particles. b) Pump partly blocked by particles (see "Cleaning the Pumps"). c) Discharge pipe partly blocked. Check the check valve, if fitted. d) Check the wear plate and the impeller for wear (see "Cleaning the Pumps").
4. Pump runs but gives no water.	a) Strainer blocked by particles. b) Pump partly blocked by particles (see "Operation and Maintenance"). c) Discharge pipe partly blocked. Check the check valve, if fitted. d) Liquid level is too low. During starting, the liquid level must be above the strainer. e) The float switch cable length is set too long

Installation and Operation

Non-Return Check Valve Recommended

Whenever the pump is installed in a permanent installation with a float switch, a non-return check valve must be fitted in the discharge pipe or hose.

Adjusting the Float Switch

The float switch can automatically turn the pump on and off. Switching adjustment is possible by repositioning the float switch in the handle of the pump. The free cable length must always be:

KP 150 & 250

- At least 2 1/2 inches
- No more than 6 inches

AP 12

- At least 4 inches
- No more than 14 inches

For manual operation, unplug both the pump and floatswitch from the 115V outlet. Plug the 115V plug on the pump into the outlet.

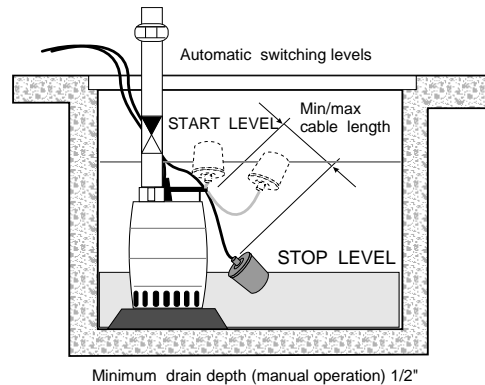

Basin Requirements

When the pump is installed in a permanent installation with a float switch, and the cable length is set to the minimum length as listed above, the minimum dimensions of the well should be as shown below. Furthermore, the well should be dimensioned according to the relation between the water flow to the well and the pump capacity.

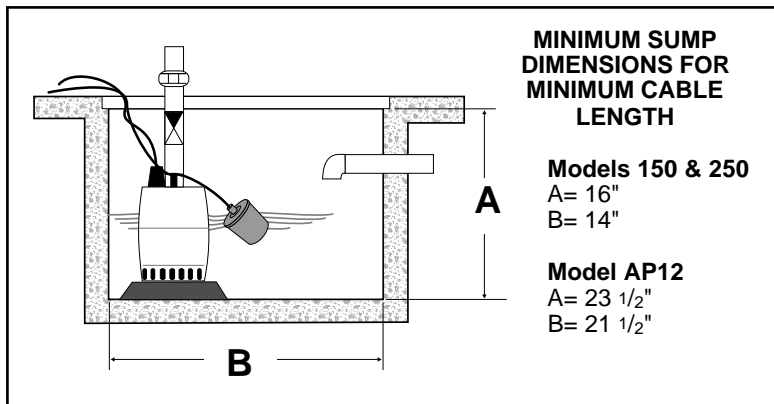

Installation and Operation

Starting "The AP/KP"

Before starting the pump, check:

- Whether the pump is submerged in liquid. During normal operation, the strainer of the pump must be below the surface of the liquid.
- Whether the pump is positioned on a base so that the strainer is not blocked by silt, mud or similar materials.
- Whether the pipe/hose connection is tight.
- Whether the discharge pipe is open (bend of hose, etc).
- Whether the pump is connected to the electric supply in accordance with the instructions.
- Check the float switch for free movement.

Then:

- Switch on and check to make sure the pump operates properly, that water is being pumped, and the pump operates through the control sequence.
- The float switch will allow the pump to pump down to a level of approximately 4". To pump out below this level secure the switch in the manual position. See Adjusting the Float Switch.

Maintenance

Regular Maintenance

Under normal operating conditions, "The AP/KP" is maintenance free. It is always advisable to flush the pump after each use, particularly if it has been pumping liquids containing particles that may settle in the pump.

Cleaning the Pump

If the pump does not deliver a sufficient quantity of water because of sediment, dismantle and clean the pump. To dismantle the pump:

1. Disconnect the electrical supply. Allow the pump to drain.
2. **KP 150 & 250** — (Refer to Fig.1 Pg.6) Carefully loosen the suction strainer by inserting a screwdriver in the recess between the outer casing and the strainer and pressing it hard. Repeat until the strainer is free and can be removed.
3. **AP 12** — (Refer to Fig.2 Pg.7) Carefully loosen the strainer by inserting a screwdriver through one of the holes of the strainer and press it downwards (towards bottom). Repeat the procedure until the strainer is free and can be removed.
3. Remove the suction strainer, clean, and refit it. Connect the electricity supply and start the pump.

If the pump still doesn't deliver sufficient water, then:

4. Disconnect the electricity supply.
5. **KP 150 & 250** — (Refer to Fig.1 Pg.6) Turn the pump housing 90° counter-clockwise using a screwdriver. Pull off the housing. Clean and flush the pump with water to remove possible impurities between the motor and the outer casing. Clean the impeller by spraying it with a hose. Check to make sure the impeller can rotate freely. If not:
 - a. Hold the impeller in place with a screwdriver while slackening and removing the nut on the motor shaft (13mm).
 - b. Clean the impeller and around the shaft.

Maintenance

Check the impeller, the housing, and the gasket. Assemble the pump in reverse order of dismantling. When doing so, check to make sure the sealing part of the housing is positioned correctly. Moisten the gasket with water to facilitate the fitting.

6. **AP 12** — (Refer to Fig.2) Unscrew the six screws close to the edge of the pump sleeve and lift the pump housing out of the pump sleeve. Clean the pump housing, the pump, and the impeller. Check to make sure the impeller can rotate freely. If not:
 - a. Hold the impeller in place with a screwdriver while slackening and removing the nut on the motor shaft (13mm).
 - b. Clean the impeller and around the shaft. Check the impeller and around the shaft. If the impeller is worn or defective, install a new one. Assemble the pump in reverse order of dismantling. Do so by:
 - c. Fit the impeller with the washer and nut. Make sure the impeller engages with the shaft.
 - d. Position the O-ring in the pump sleeve and lower the pump into the intermediate chamber.
 - e. Fit the six screws with gaskets in the pump housing and tighten securely.

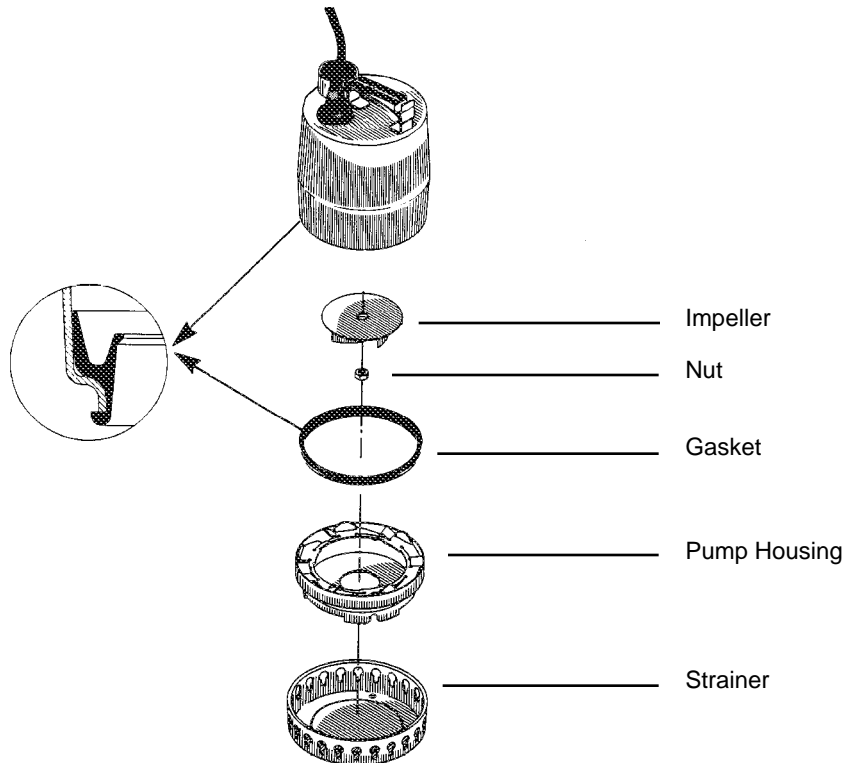
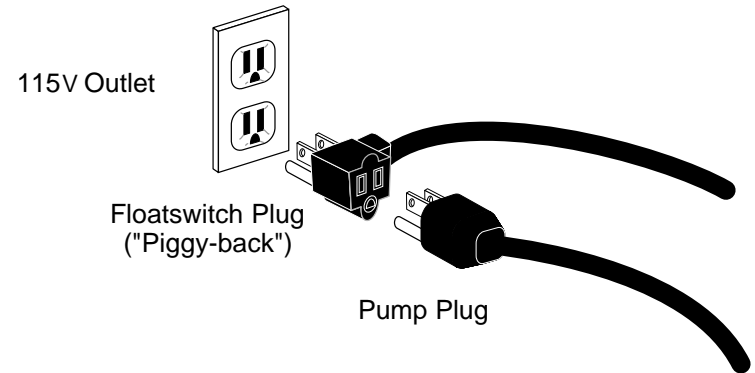

Fig. 1 KP 150 & 250

Installation and Operation

When connecting the pump for manual operation, the 115V plug is inserted into a 115V outlet. If a floatswitch is included for automatic operation it will be of the "Piggy-back" design. Plug the 115V plug on the floatswitch into the 115v outlet then plug the 115V plug from the pump into the floatswitch plug.



Pump Location and Positioning

Before positioning the pump, make sure that the strainer will not be blocked or partly blocked by silt, mud, or similar materials. This can be avoided by positioning the pump on bricks or a concrete pad, or by letting the pump hang from the discharge pipe or a cable 2-4 inches above the bottom.

"The AP & KP" can be used in the following positions:

When used in the horizontal position, the pump must be completely covered by liquid, and discharge port at the highest position on the pump (as shown).

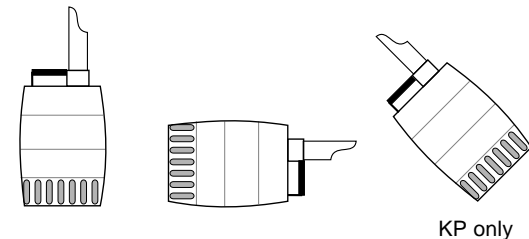

Pipe Connection

Steel or rigid plastic pipe can be screwed directly into the 1 1/4" inch NPT for KP, 1 1/2" inch NPT for AP12 pump discharge port. For permanent installation, a union fitting at a convenient point is recommended to facilitate ease of removal for cleaning and servicing. A few other recommendations:

- For portable or temporary installations, plastic discharge pipe can be used in conjunction with a suitable screwed/hose connector.
- Removal of the pump should be by a cable secured to the pump handle and not by the discharge pipework.
- Screwed threads should be sealed using Teflon® tape.